



OPTIME Gateway 2

User manual

OPTIME GATEWAY 2

Contents

OPTIME Gateway 2.....	1
About the user manual.....	2
Signal words and symbols.....	2
Other symbols	3
Legal guidelines	3
Advice on third party products and services.....	3
General safety guidelines	4
Principles.....	4
Marking.....	4
Usage for the intended purpose	4
Usage not for the intended purpose	4
Warranty.....	4
Selection and qualification of personnel.....	5
Work on electrical devices.....	5
Safety regulations.....	5
Explosive environments	7
Scope of delivery	7
Gateway	7
Required accessories.....	8
Damage during transit.....	8
Defects	8
Description	8
Structure.....	8
Planning	9
Gateway connections and indicators	10
Install gateway	11
Add the gateway to the mesh network	11
Install the gateway to the installation location	11
Electrical connections.....	13
Changing the SIM card.....	16
Gateway communication interface.....	16



LED operation modes and status indication	17
In operation mode	18
In debug mode	18
Status indication for gateway configuration	19
Gateway configuration	20
Login to gateway configuration UI	20
Gateway configuration UI	24
Configure gateway settings	29
Change the language of the UI	35
Exit the configuration session.....	36
Troubleshooting and rectification	36
Cleaning	37
Nameplate	37
Technical data	37
Gateways dimensions	39
Appendix	40
EU Declaration of Conformity.....	40
UK Declaration of Conformity.....	41

About the user manual

This user manual applies to the OPTIME Gateway 2 (called device in the following text).

Signal words and symbols

The warning and hazard symbols are defined in accordance with ANSI Z535.6-2011

- 
WARNING In case of non-compliance, death or serious injury may occur. Consult the documentation in all cases of occurrence of this symbol.
- 
WARNING In case of non-compliance, death or serious injury may occur due to electrical hazards.
- 
CAUTION In case of non-compliance, minor or moderate injury may occur. Consult the documentation in all cases of occurrence of this symbol.
- NOTICE** In case of non-compliance, damage or malfunctions in the product or the adjacent construction may occur.

Other symbols

Class II Protection

This device provides a double insulation. The double insulation is only provided when the device is hermetically closed, and the cover is not removed.

Legal guidelines

The information in this manual corresponded to the most recent status at the close of editing. The illustrations and descriptions cannot be used as grounds for any claims relating to devices that have already been delivered. Schaeffler Monitoring Services GmbH accepts no liability for any damage or malfunctions if the device or accessories have been modified or used in an incorrect manner.

Apps and functions may not be available in all countries and regions. The availability of apps and functions may change.

Advice on third party products and services

All names of products and services cited in this manual are brand names of the respective companies. The details provided in the text are merely indicative and provided for information purposes only.

- Apple, App Store, Safari and their logos are registered trademarks of Apple Inc.
- Google, Android, Google Play, Google Chrome and their logos are registered trademarks of Google LLC
- Microsoft, Windows, Edge, Internet Explorer, Excel and their logos are registered trademarks of the Microsoft Corporation
- Mozilla, Mozilla Firefox and their logos are registered trademarks of the Mozilla Foundation
- Wirepas, Wirepas Mesh and their logos are registered trademarks of Wirepas Ltd.

The information given in this publication cannot be construed as constituting any related liability for products and services not produced or provided by Schaeffler Monitoring Services GmbH. Schaeffler Monitoring Services GmbH does not take ownership of these products and services.

Other products and manufacturers' names cited in this publication may be the trademarks of their respective owners.

Licences

The software uses third-party provider libraries under their respective licences.

For more information about the libraries used, including their respective licence conditions, see the [Show open source licenses] option in the [

Support data] section of the gateway software.

General safety guidelines

This chapter brings together all the important safety regulations.

Any person charged with working on the system must read this chapter and observe the guidelines.

Principles

The OPTIME Gateway 2 corresponds to the current level of technology and the recognised rules of safety practice. If the safety guidelines are not observed, risks to life and limb for the user or third parties and extensive damage to other material assets may nevertheless arise during use.

Marking

Every gateway of the OPTIME condition monitoring system is marked with a serial number. The gateway nameplate contains the serial number, a QR code, information on the manufacturer and the CE symbol.

Usage for the intended purpose

The OPTIME Gateway 2 is approved for use in indoor and outdoor industrial environments. The system may only be used in accordance with the technical data, see page 37. Unauthorized structural modifications to the system are not permissible. We assume no liability for any damage to machinery or Injury to persons arising from such actions.

Usage for the intended purpose also includes the following:

- all guidelines in the user manual are observed
- compliance with all relevant specifications on occupational safety and accident prevention during all life cycles of the system
- the necessary specialist training and authorisation of your company for carrying out the necessary work on the system.
- All work may only be performed by a skilled person

Usage not for the intended purpose

The OPTIME Gateway 2 does not provide machine protection. It must not be used as a component of safety systems. The OPTIME Gateway 2 is not classified as a safety component in accordance with the EU Machine Directive 2006/42/EC.

Warranty

The manufacturer shall assume liability for warranties in relation to operational security, reliability, and performance only under the following conditions:

- Installation and connection must be carried out only by skilled personnel.

- The system must be used in accordance with the information in the technical data sheets. The limit values indicated in the technical data must not be exceeded under any circumstances.
- Conversion and repair work on the system may only be carried out by the manufacturer.

Selection and qualification of personnel

The OPTIME condition monitoring system may only be mounted, commissioned and operated by qualified skilled personnel. The scope of competence, area of responsibility and monitoring of personnel must be precisely regulated by the site operator.

Designated qualified skilled personnel:

- are authorised to install the system
- have all the necessary knowledge
- are familiar with the safety guidelines
- have read and understood this manual.

If skilled personnel do not possess the necessary knowledge, they must be given the necessary training and instruction. Schaeffler can offer appropriate training courses on request.

Work on electrical devices

Work on electrical devices may only be carried out by a trained and skilled electrician.

On the basis of their technical training, knowledge and experience as well as their knowledge of the appropriate regulations, a trained and skilled electrician is in a position to assess the work assigned to them and recognise possible hazards.

Do not repair any damaged system components. Please arrange for any necessary repairs to be carried out by Schaeffler Monitoring Services GmbH.

Any work on wiring, opening or closing of electrical connections may only be performed when the device is disconnected from the power supply and in a voltage-free state.

Safety regulations

All safety specifications are described in the following sections.

Safety during installation

Read this user manual before installing the system. Make sure you are certain that the product is suitable without restrictions for the relevant applications.

Before installing the components, check for any external damage. If damage or some other defect is found, the system must not be commissioned.

Any interventions in and modifications to the system, or the addition or removal of components not designed to be added or removed, are impermissible, can endanger occupational safety and may render any warranty claim null and void.

The device may only be installed by a trained and skilled electrician who observes the national and international regulations covering the installation of electro-technical equipment.

Radio interference and electromagnetic interference

Radio interference can be caused by any device that emits electromagnetic signals. With so many devices transmitting and receiving radio waves, interference can occur if radio waves are overlapping.

Do not use the gateway in places where the use of radio equipment is prohibited.

Consult your doctor and the manufacturer of your medical device (pacemaker, hearing aid, electronically controlled implant, etc.) to find out if it may be affected by the gateway's interference.

Handling the backup battery in the gateway

The gateway contains a replaceable backup battery, which are not dangerous provided they remain enclosed in the housing. Never expose the batteries to excessive mechanical, thermal or electrical loads, as this would activate the safety valves and the battery container could rupture. Avoid temperatures of more than +70 °C. Dispose of the battery in accordance with the statutory provisions.

The incorrect handling of the gateway may result in leaks or the emission of evaporated electrolyte that can cause a fire or an explosion and lead to serious injuries or death.

This product contains a button cell battery. If the button cell battery is swallowed, it can cause severe internal burns and can lead to death.

Gateways must be deactivated during transport and storage.

Keep away from children

Gateway and sensors are not toys and must be kept out of the reach of children. The system contains small parts. Children must not be allowed to play with system components. This equipment is not suitable for use in locations where children are likely to be present.

Danger of burns due to hot surfaces

The outer surface of a machine can reach high temperatures that can cause injuries in the event of direct contact. Before performing installation work switch off the machine and allow it to cool down.

If these instructions are not followed serious injuries may result.

Safe handling of information interfaces

This product has the following information interfaces:

- 2G, 3G, 4G, Wirepas Mesh network (2.4 GHz)
- WiFi (WLAN)
- Ethernet.

The product can be connected with other devices, components or internal or external networks (e.g. internet) via each of these interfaces. Devices (like data carriers) connected via information interfaces may contain malware or execute malicious functions undetected. This product, or potentially your company infrastructure (e.g. IT infrastructure) can be damaged due to the use of these kinds of information interfaces. In addition, your company's data security may be compromised.

Before using our product and its information interfaces, please familiarise yourself with the following:

- the security features offered by the product and its information interfaces
- the security provisions of your company (e.g. on IT security).

Before commissioning, please clarify with your relevant points of contact whether and which security measures are to be taken when using the product and its associated information interfaces.

Protection against unauthorised use

Data encryption and secure login with individual login data are the tools used to protect against unauthorised use of the OPTIME app and OPTIME dashboard. Software users (users) must log in with their username and password. The password must be changed at regular intervals. A secure password must be used.

The user is responsible for keeping their login data secure.

Explosive environments

Under adverse conditions, radio waves near explosive environments may cause fires or explosions.

Do not install and operate the gateway in the vicinity of explosive environments, flammable gases, areas where the air contains chemicals or particles such as grain, dust, or metal powder, or near detonation grounds.

Scope of delivery

The OPTIME condition monitoring system is available in various combinations.

Gateway

- 1 OPTIME Gateway
- Mounting material for concrete (screws 4,5 x 40 mm plus dowels)
- 4 seal plugs
- 1 gateway quick guide manual

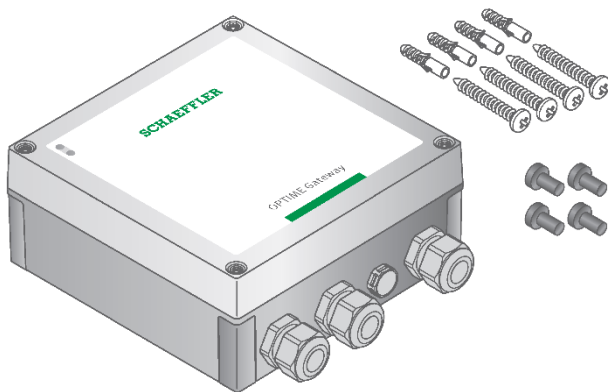

Required accessories

To ensure the system is complete and ready-to-use, the following devices and accessories need to be provided by the user in addition to the gateway and sensors:

- mobile phone or tablet (each with LTE and NFC technology) with installed OPTIME app
- connection cable to supply power to the gateway. Do not use a wire of section exceeding 1.5 mm² or 16 AWG. Do not strip the cable more than 5 mm. If a flexible wire is used, a ferrule must be used.

Damage during transit

Any damage during transit must be reported as a complaint to the carrier:

- Check the delivery immediately upon arrival for any damage during transit.
- Report any damage during transit promptly as a complaint to the carrier.

The gateway packaging does not protect the items against damage during transport.

CAUTION The electronics and plastic components of the gateway can be damaged or destroyed by strong vibrations, so avoid dropping them and severe impacts.

Defects

Any defects must be reported promptly as a complaint:

- Check the product immediately upon delivery for visible defects.
- Report any defects promptly as a complaint to Schaeffler.

Description

Structure

The overall system consists of several components designed for condition monitoring and predictive maintenance:

- OPTIME gateway

- OPTIME sensors (described in manual BA68)
- OPTIME app
- OPTIME dashboards in the Schaeffler IoT Hub.

The sensors automatically form a mesh network that transfers data directly or via other sensors to the gateway. In the network, the sensors transfer raw data on vibrations as well as key performance indicators (KPI) via the gateway to the Schaeffler IoT Hub, where the data are analysed, and the results sent to the OPTIME app.

All analyses are also available in the OPTIME dashboard. Directly after activation the sensor automatically starts to measure and transfer data at pre-set intervals. At the same time, learning mode is initiated, which defines the alarm thresholds for the respective machine.

The mesh network organises itself automatically when sensors or gateways are added or removed. The use of several gateways in the same network is also possible. Depending on the circumstances, existing OPTIME installations can also be expanded subsequently to 50 sensors per gateway.

Since an independent network is used to transfer the measured data to the Schaeffler IoT Hub and wireless technology is used for other communication (pre-set, optionally also Wi-Fi or Ethernet), there is no need for a connection to the local IT infrastructure.

Communication interfaces and data transfer of OPTIME system

Mesh technology was selected because when monitoring the condition of machines in large industrial plants large distances also have to be covered and difficult to access machines need to be reached. The actively managed mesh network can establish contact to sensors in a line of sight of up to 100 m, ensures reliable communication and at the same time optimises the battery service life of the sensors.

The standard version of the gateway already has an integrated SIM card for use exclusively in conjunction with the OPTIME system. If the proposed mobile phone connection is not to be used, there are other options for connecting to the Schaeffler IoT Hub, i.e. using a separate SIM card, a Wi-Fi connection or connection via network cable.

Planning

A system tree, i.e. showing the allocation of sensors to machines and assets, does not necessarily have to be set up beforehand. However, in the case of an entire plant this considerably simplifies the installation process, as it is only necessary to select the corresponding machine for sensor installation. A system tree may take the form of an Excel table imported via the dashboard menu.

Registering the OPTIME dashboard

To configure the gateway and sensors it is necessary to register in the Schaeffler IoT Hub, so that sensors and gateways are automatically associated with your company. You can configure the components of your system, i.e. gateway and sensors, for your system tree. This can be done following completion of registration either in the OPTIME dashboard or in the OPTIME app.

OPTIME app installation

Before installing the components of the OPTIME system, you will need to install the OPTIME app on your mobile phone or tablet. The OPTIME app can be downloaded free of charge

from the App Store or Google Play. You will need login data to be able to log on to the OPTIME app.

Log into the OPTIME app and OPTIME dashboard

Every customer receives an administration user account when purchasing the OPTIME system. This user is able to create additional users. All created users will receive their login data by e-mail. To log into the OPTIME customer portal, please visit the following website: <https://schaeffler-optime.com/dashboard>

Gateway connections and indicators

The gateway is equipped with three cable glands for feeding through the cable to the power supply and optionally the cables for network connection or external antennas.

Antennas with SMA connectors and local LTE certification can be used.

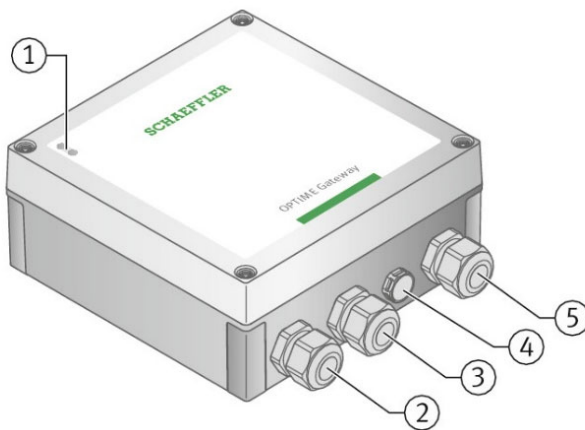

Figure 1 Gateway connections and indicators

1. LED indicators
2. Network connection / external LTE antenna
3. Network connection / external LTE antenna
4. Protective vent
5. Input power supply

NOTICE (2) and (3) can both be used for either purpose, and (5) should be used for powering.

NOTICE Do not remove the protective vent (4).

The two LED indicators (1) on the gateway show various operating statuses (see LED operation modes and status, page 17).

Install gateway

The gateway is mounted in a protective housing suitable for wall or ceiling installation. It can also be installed outdoors due to its protection type and UV resistance.

The gateway is the core of the mesh network; it is recommended to install it prior to any OPTIME sensor. The gateway is

- added to the mesh network (see Add the gateway to the mesh network, page 11),
- installed at the desired location (see Install the gateway to the installation location, page 11), and
- the electrical installation is completed (see Electrical connections, page 13).

Add the gateway to the mesh network

The OPTIME app guides you through the process of adding the gateway to the mesh network:

1. Open the OPTIME app.
2. Tap the [Login] button.
3. Enter your login data.
4. Go to the menu and tap the [Add Gateway] button.
5. Follow the instructions in the OPTIME app to scan the QR code of the gateway.

Install the gateway to the installation location

Install the gateway at a central location in the overall OPTIME setup.

Note the following for the installation location:

- Place the gateway in a central location in the area of the installed sensors. There should be a line of sight to five or six sensors, which can then be used as repeaters for the remaining sensors. For optimum coverage, install the gateway above the sensor level.
- Avoid installing the gateway at the end of a row of several sensors one behind the other to prevent the last sensor in the row from having a reduced battery life.
- When selecting the installation location, make sure that no reinforced concrete or larger metal objects can block signal transmission in the installation area. Select an installation location that allows stable data transmission.

NOTICE Do not install the gateway inside a metal switch cabinet.

- If a cellular connection is used for data transfer, check the LTE reception at the installation location beforehand with a mobile phone.

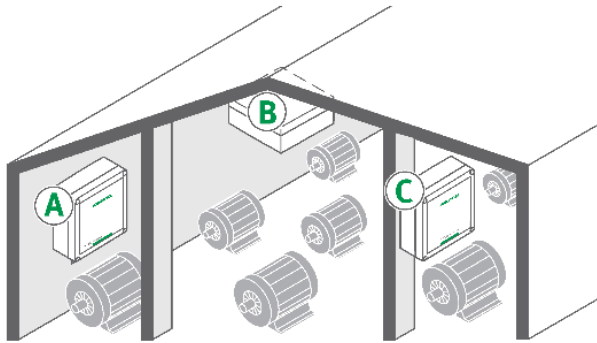

Figure 2 Installation location for the gateway

Installation brackets are supplied with the gateway.

NOTICE Suitable fixing material is included in the scope of delivery. If you use own fixing materials, please ensure that the screws have a minimum length of 40 mm.

Install the gateway to the selected location using the installation brackets.

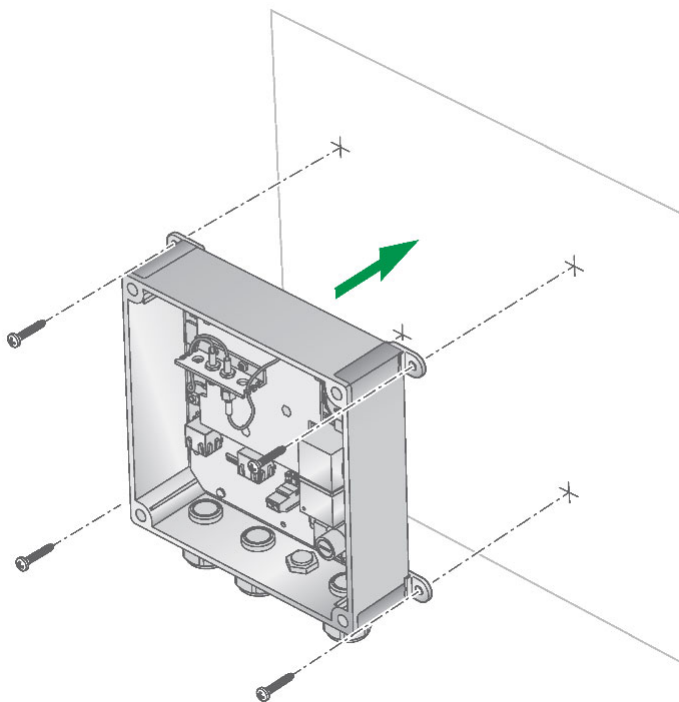

Figure 3 Installing the gateway

Electrical connections

- ⚠ WARNING** Only a qualified and skilled electrician is allowed to open the gateway's housing, to install and commission the gateway and to connect the mains voltage or exchange the fuse or battery.

- ⚠ WARNING** Failure to adhere to the safety regulations can cause a life-threatening electric shock. Make sure that all electrical connections are carried out only by skilled personnel who observe the safety regulations.

- ⚠ WARNING** A defective connection cable can cause a life-threatening electric shock. Change any defective connection cables immediately.

- ⚠ WARNING** An easily accessible and appropriate disconnect device must be provided as part of the building installation to completely disconnect the device from the mains installation.

- ⚠ WARNING** The device may only be opened in an environment of pollution degree 2 or 1.

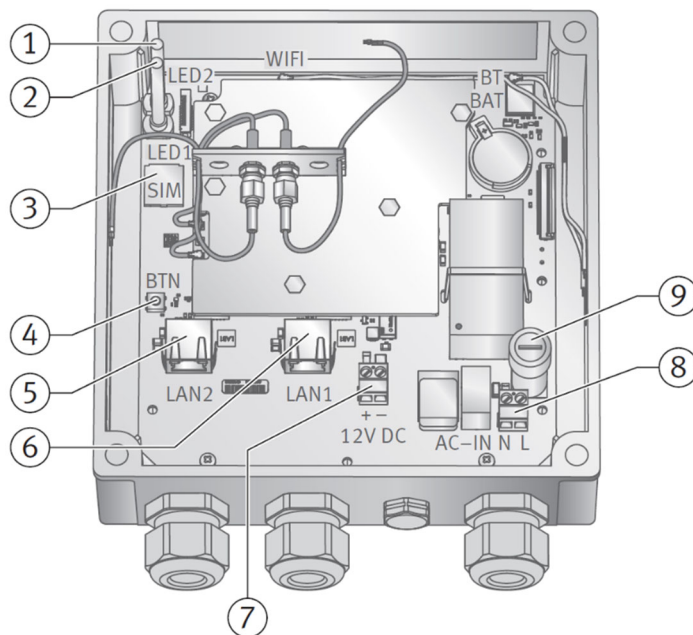

Figure 4 Gateway with the cover opened 1

1. LED 2
2. LED 1
3. SIM card slot
4. Push button
5. LAN2
6. LAN1
7. Alternative power supply (DC power supply)

8. Main power supply (AC power supply)
9. Fuse

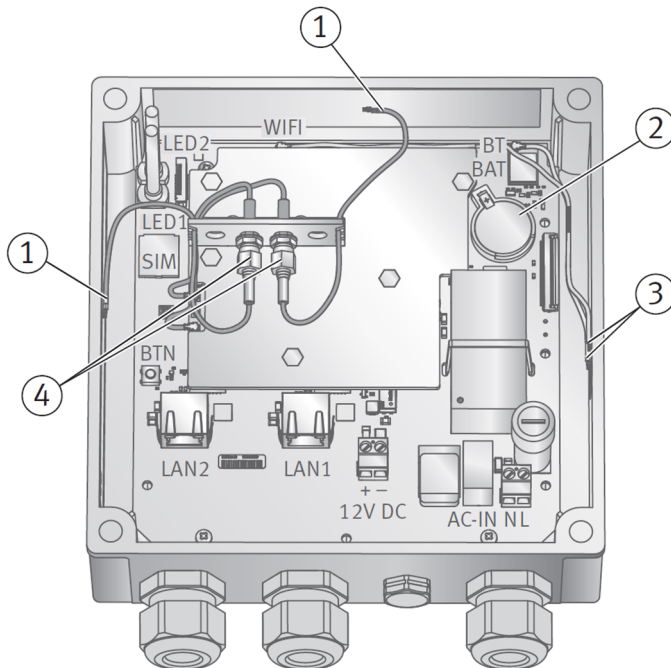

Figure 5 Gateway with the cover opened 2

1. LTE antennas
2. Backup battery (RTC)
3. Combined antenna (Bluetooth, Wi-Fi)
4. SMA connectors (LTE)

To connect the electrical connections:

1. Open the cover of the gateway.

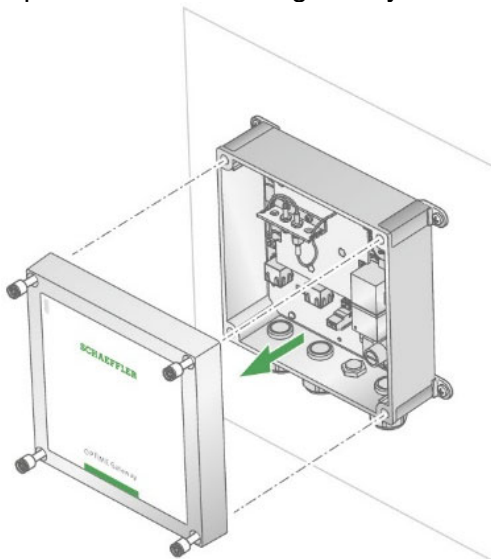

Figure 6 Opening the cover of the gateway

2. Connect the power supply.

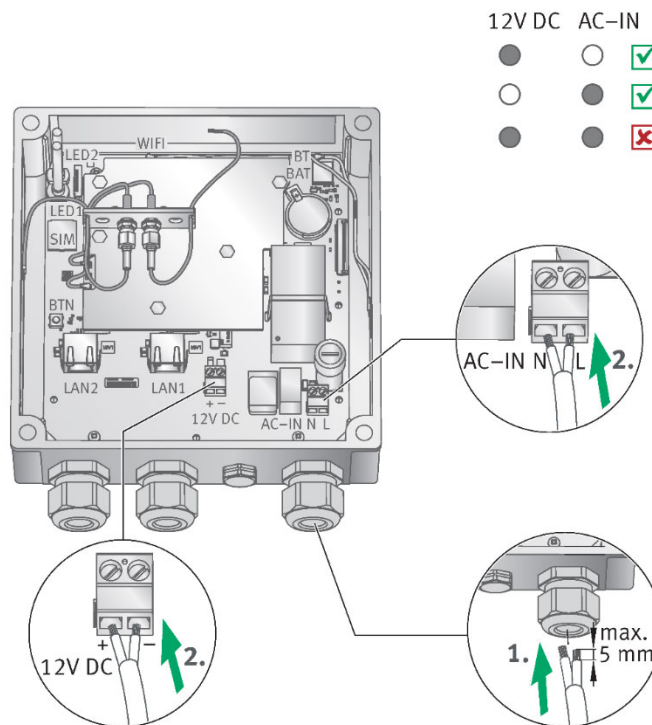

Figure 7 Power supply connections

NOTICE The mains input (AC-IN) and the alternative 12 V DC input must not be connected in parallel.

'Line' and 'Neutral' for AC-IN must be connected as marked on the PCB (see (8) in Figure 4 on page 13). Do not use a wire of section exceeding 1.5 mm² or 16 AWG. Do not strip the cable more than 5 mm. If a flexible wire is used, a ferrule must be used.

3. Connect the network connections LAN1 (LAN2 for future use).

NOTICE Network connections are by default physically disabled. They can be enabled via the Gateway configuration UI.

The gateway is now connected.

- If the cellular connection is used (factory setting), a SIM card needs to be placed into the SIM card holder. The SIM card is either provided by Schaeffler or the customer. Then the gateway connects automatically with the Schaeffler cloud. It may take several minutes to establish the connection.
- If the gateway is to be connected via the LAN, you can alternatively establish communication with the gateway by plugging the network cable connector into the router socket.
- When LED1 on the gateway turns green an Internet connection is established. When also LED2 turns green, the gateway appears in the customer section in the Schaeffler cloud.

Changing the SIM card

1. Make sure that the gateway is switched off. Wait at least 30 s before opening the gateway's housing.
2. Open the cover of the gateway. See Figure 4 on page 13 for the location of the SIM card slot.
3. Observe the lock symbols on the lid of the SIM card holder.

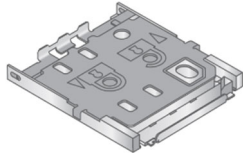

Figure 8 Lock symbols on the SIM card holder

4. Open the lid of the SIM card holder by carefully pressing a finger on top of the lid and sliding it into the unlocked position.
5. Lift the lid upwards.
6. Remove the old SIM card, if any.
7. Slide in the new SIM card to the lid of the holder so that the contacts of the SIM card are visible.

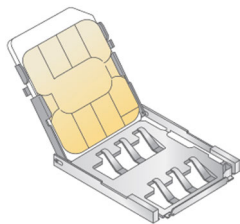

Figure 9 SIM card in the holder

8. Close the lid of the holder and slide it into the locked position (it will snap).
9. Close the cover of the gateway.

After complete commissioning, insert the plugs provided to seal the device.

Gateway communication interface

The main function of the gateway is to transfer data between the sensor mesh network and the OPTIME backend.

Various interfaces are available for communication between the gateway and Schaeffler cloud. Cellular communication is used by default.

The following communication options are available:

- Cellular (default)
- Wi-Fi
- LAN (Ethernet)

For details on the communication settings, see Configure gateway settings, page 29.

LED operation modes and status indication

The gateway has 2 LED indicators that show various statuses depending on the operating mode.

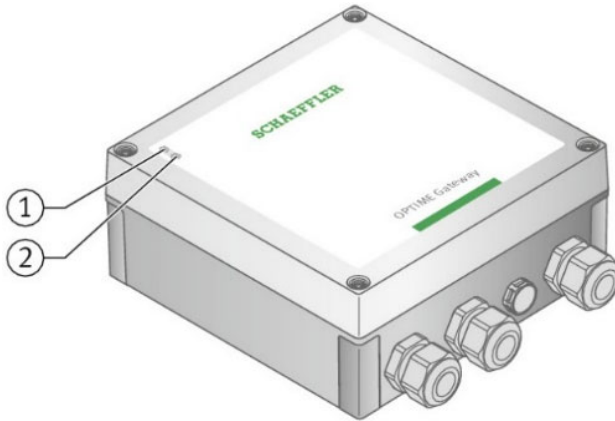

Figure 10 LED indicators

1. LED 2
2. LED 1

There are two operating modes:

- In operation mode
- In debug mode

In addition to the two operating modes, the LED indicators show the time window to open access to the gateway configuration by pushing push button (only available during the start-up of the gateway indicated by a blue **LED 1**).

NOTICE The gateway itself has only one main operation mode. After the gateway is started in normal operation, it transfers data between the mesh network and backend, regardless of whether the LED indicators are in the operation mode or debug mode, or if the configuration UI was accessed in the start-up phase.

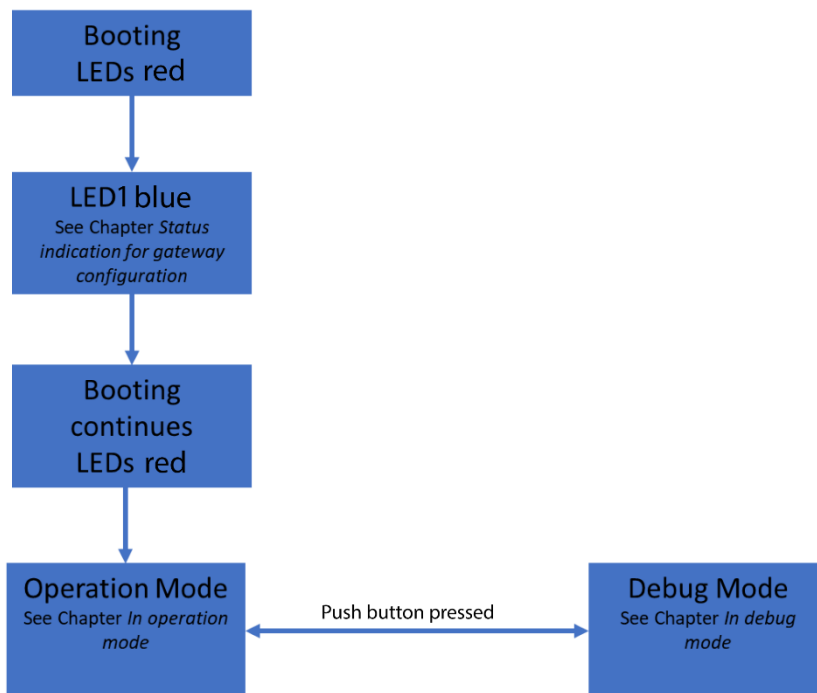

Figure 11 LED operation modes and status indication

In operation mode

When the gateway is in the operation mode, the LED indicators show the operating status.

Table 1 Operating mode LED indicators

LED2	LED1	Function
Green light		A connection between the gateway and the OPTIME backend has been established.
	Green light	The gateway is connected to the Internet.
Red light		The connection to the OPTIME backend is not established.
	Red light	The connection to the Internet is not established.

In debug mode

Examine the quality of the Internet connection by pressing the blue push button during operation. The LED indicators show the status of the connection.

Table 2 Debug mode LED indicators

LED2	LED1	Function
Flashing green		A good Internet connection
Flashing yellow		A bad Internet connection
Flashing red		No Internet connection
	Flashing pink	4G Internet connection
	Flashing blue	3G Internet connection
	Flashing yellow	2G Internet connection

Status indication for gateway configuration

NOTICE Access to the configuration UI is only available during start-up of the gateway.

When you switch on the gateway, both LED indicators are red. When the LED1 turns blue (for 5 s), you can enable access to the configuration UI by pushing the push button on the gateway (while the LED is blue).

NOTICE The gateway continues the start-up and enters the operation mode regardless of whether you enter the configuration UI or not.

When you start the configuration mode in the gateway, the LED indicators show the status of the gateway acting as a Wi-Fi access point.

Table 3 Configuration mode LED indicators

LED2	LED1	Function
	Blue light	You can start the configuration mode in the gateway by pressing the push button.
	Green light	A flashing green light indicates that the gateway provides a Wi-Fi access point.

For details on how to put the gateway to the configuration mode, see Gateway configuration, page 20.

Gateway configuration

NOTICE Normally there is no need to change the standard gateway settings. But for certain installations it may be necessary to adapt or change some of the standard settings. Only skilled personnel are allowed to change these settings.

NOTICE The gateway can be put into the configuration mode only during start-up. If the gateway is in operation, you must reboot the gateway.

You can use the browser in a mobile device (mobile phone, tablet) or a computer with Wi-Fi connection to make the changes.

Login to gateway configuration UI

Before you start, you need a Wi-Fi password.

1. To get the Wi-Fi password, start the Schaeffler OPTIME mobile app on your mobile device and log in.
2. On the start page, select the [Menu] icon in the top left corner.

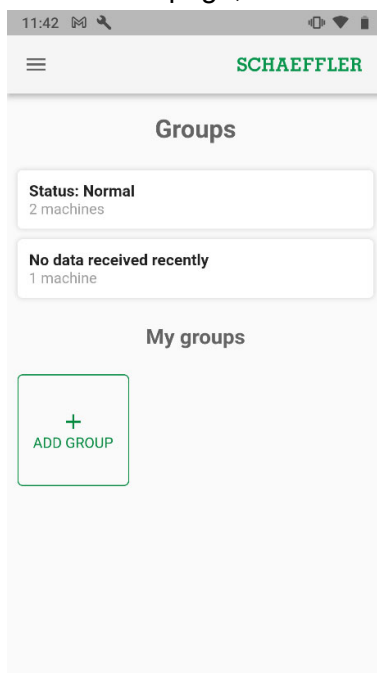

3. Select [Scan device] from the Menu.

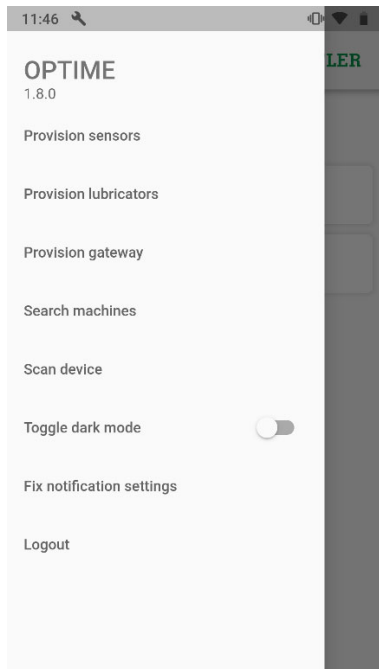

4. Select [Scan gateway].

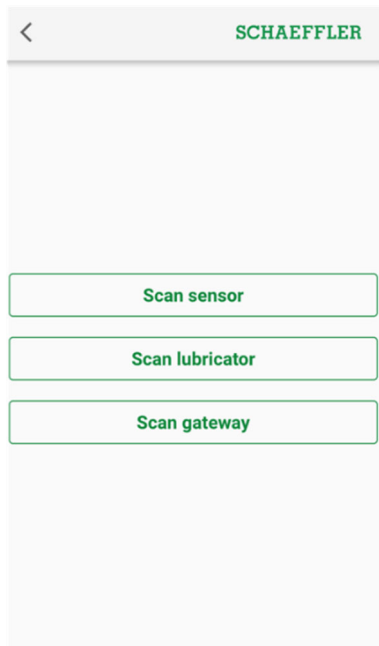

The QR code scanner opens.

5. Select [Scan QR code].



The camera opens.

6. Scan the QR code on the nameplate of the gateway.

As a result, you receive the Wi-Fi password and other information on the gateway.

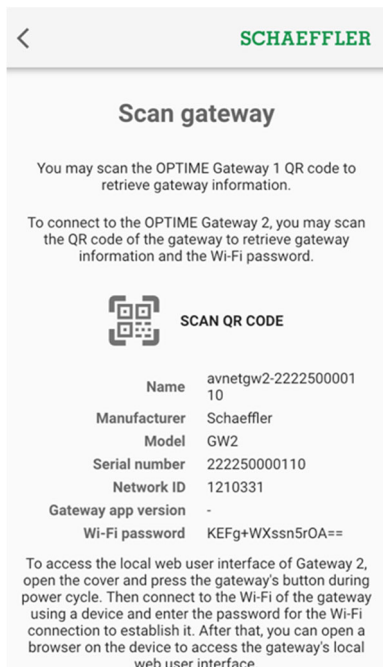

7. Copy the Wi-Fi password.

To access the gateway configuration user interface (UI) using a browser in a mobile device or a computer:

1. Switch on the gateway and wait until the LED indicator is blue.
2. While the LED indicator is blue, press the [Push] button on the gateway.

A green LED flashes to acknowledge that the [Push] button was pressed.

The gateway is now in the configuration mode and provides a Wi-Fi access point.

3. Select the Wi-Fi access point from the WLAN list on your computer or mobile list to establish a Wi-Fi connection between your computer or mobile device and the Wi-Fi access point.

The name of the Wi-Fi access point is “OptimeGateway<serial number>”, where <serial number> is the serial number of the gateway.

The serial number is on the label on the side of the gateway.

4. Enter the Wi-Fi password when requested by the system.
5. Open your browser and enter the IP address `http://192.168.111.1`

The gateway configuration UI start page opens.

NOTICE Some Android phones will automatically change to 'mobile data', when you are connecting to the configuration UI through the Wi-Fi access point. If this happens, disable the mobile data before you access the gateway configuration.

NOTICE If you use a Windows PC to access the gateway configuration UI, select the Wi-Fi access point from the WLAN list and press [Connect].

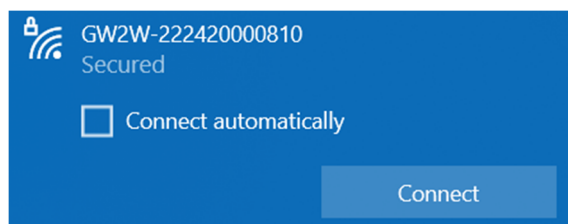

Select “Connect using a security key instead”:

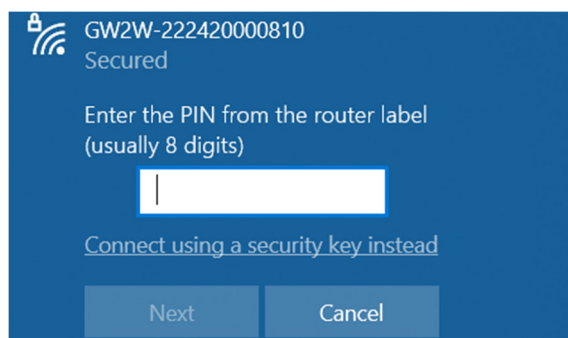

Enter the Wi-Fi password and press [Next]:

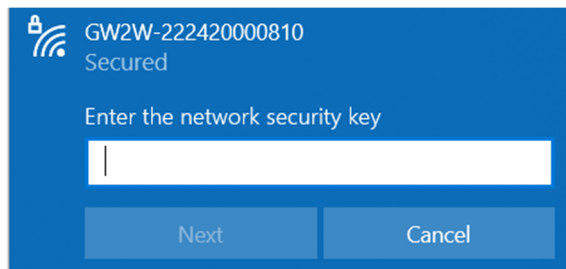

For details on the UI, see

Gateway configuration UI, on page 24.

You can now change the configuration. For details, see Configure gateway settings, page 29.

The connection ends after 10 minutes of inactivity, or if the [Exit] icon is pressed.

NOTICE The hotspot deactivates when you leave the configuration UI. To activate it again, reboot and redo the Login to gateway configuration UI procedure from page 23 onwards.

Gateway configuration UI

On the start page of the gateway configuration UI, you can see:

- The network status and the current settings
- Device configuration data
- Support data

NOTICE You can only view the network status and settings on the start page. To change the configuration, press the [Settings] icon at the top of the page. For details, see Configure gateway settings, page 29.

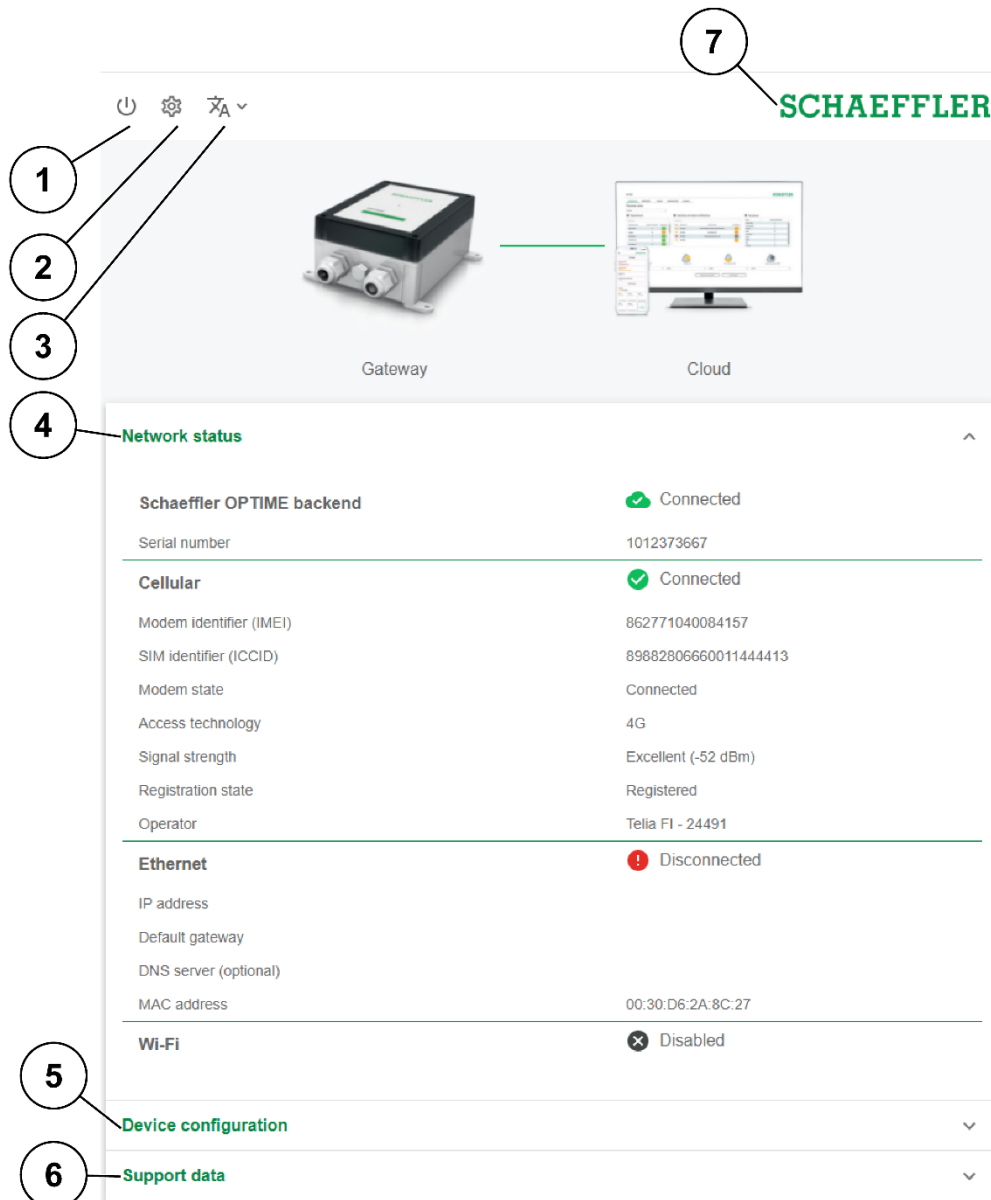

Figure 12 Start page of the configuration UI: 1 Exit, 2 Settings, 3 Language selection, 4 Network status, 5 Device configuration, 6 Support data, 7 Home

Designation	Description
(1) Exit	Exit the configuration session. The Wi-Fi access point will no longer be accessible until the next reboot.
(2) Settings	Press the [Settings] icon to access the gateway settings.
(3) Language selection	Select the language for the user interface.
(4) Network status	Shows the current network connection status.
(5) Device configuration	Shows the current gateway settings.

(6) Support data	Download log files and view the license information.
(7) Home	Press the Schaeffler logo to return to the status page.

Network status

The Network status section shows the status of the communication interface between the gateway and cloud.

Network status

Schaeffler OPTIME backend	Connected
Serial number	1012373667
Cellular	Connected
Modem identifier (IMEI)	862771040084157
SIM identifier (ICCID)	89882806660011444413
Modem state	Connected
Access technology	4G
Signal strength	Excellent (-52 dBm)
Registration state	Registered
Operator	Telia FI - 24491
Ethernet	Disconnected
IP address	
Default gateway	
DNS server (optional)	
MAC address	00:30:D6:2A:8C:27
Wi-Fi	Disabled

Device configuration

Support data



Figure 13 Network status, cellular connection established

At the top of the page, the colour of the line between the gateway and cloud images shows the connection status between the gateway and Schaeffler OPTIME backend:

- Green line: Connected.
- Red line: Disconnected.

NOTICE If the connection was established (green line) but later the Internet connection was lost, the colour of the line does not change back to red.

SCHAEFFLER

Gateway
Cloud

Network status ^

Schaeffler OPTIME backend	🔴 Disconnected
Serial number	1012373667
<hr/>	
Cellular	🔴 Disconnected
Modem identifier (IMEI)	862771040084157
SIM identifier (ICCID)	89882806660011444413
Modem state	Connecting
Access technology	4G
Signal strength	Excellent (-48 dBm)
Registration state	Registered, roaming
Operator	Telia FI - 24491
<hr/>	
Ethernet	🔴 Disconnected
IP address	
Default gateway	
DNS server (optional)	
MAC address	00:30:D6:2A:8C:27
<hr/>	
Wi-Fi	⊗ Disabled

Device configuration v

Support data v

Figure 14 Network status, connection status: Disconnected

Device configuration

The Device configuration section shows the current gateway settings.

The screenshot displays the SCHAEFFLER web interface for device configuration. At the top, there are navigation icons (power, settings, and a dropdown menu) and the SCHAEFFLER logo. Below the navigation is a diagram showing a physical Gateway device connected to a Cloud server. The main content area is divided into sections: 'Network status' (collapsed), 'Device configuration' (expanded), and 'Support data' (collapsed). The 'Device configuration' section features a green 'DOWNLOAD' button and a list of settings for Cellular, Ethernet, Wi-Fi, and Time.

Category	Setting	Value
Cellular	Select operator automatically	Yes
	Operator	Telia FI - 24491
	Roaming	Yes
	Network mode	4g
	Configure APN automatically	No
	Access Point Name (APN)	iot.1nce.net
	APN Username	
Ethernet	DHCP enabled	Yes
	DNS server (optional)	
Wi-Fi		Disabled
Time	Set date & time automatically	Yes
	NTP server	pool.ntp.org
	Time zone	Universal

Figure 15 Device configuration data

To download the gateway configuration data in .txt format, press [Download].

Support data

In the Support data section you can:

- Download log files, for example, to be delivered to the Schaeffler support team.
- View the licence information.

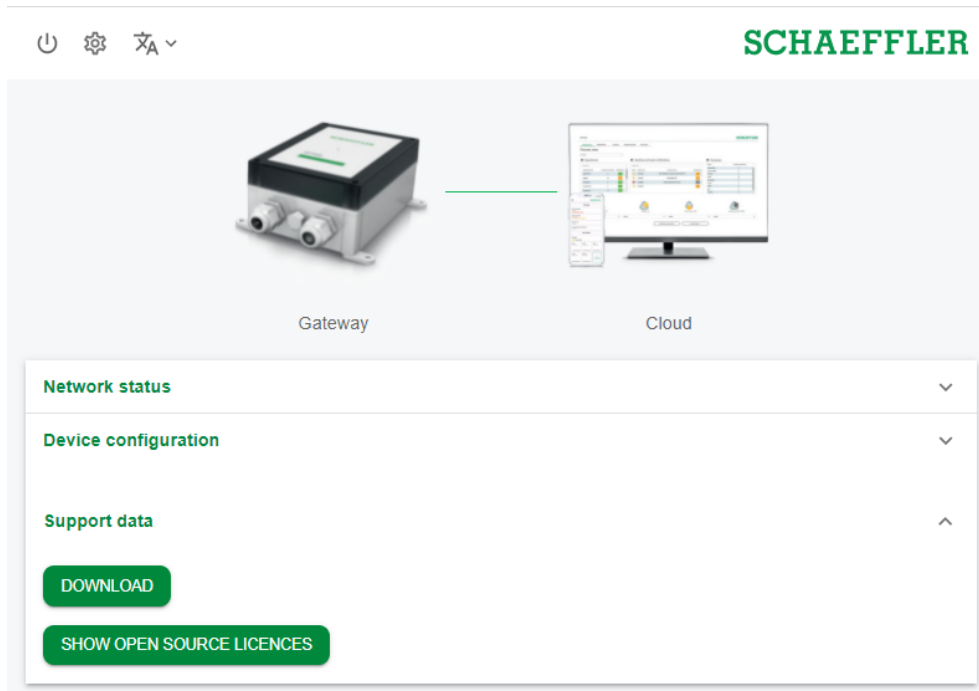

1. Press [Download] to download a .zip file that contains the encrypted log files.
2. Press [Show open source licences] to view the licence information in .html format.

Configure gateway settings

NOTICE Normally there is no need to change the standard gateway settings. But for certain installations it may be necessary to adapt or change some of the standard settings. Only skilled personnel are allowed to change these settings.

To access the gateway settings:

1. Press the [Settings] icon in the configuration UI.
2. Select the settings that you want to change.

The following settings can be changed:

 - Cellular
 - LAN (Ethernet)
 - Wi-Fi
 - Date and time

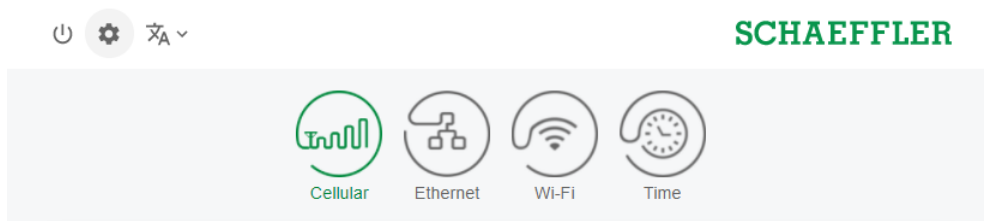

Figure 16 Gateway settings icons

Designation	Description
Cellular icon	Opens the cellular (SIM) settings.
Ethernet (LAN) icon	Opens the LAN settings. If the gateway is to be connected with a local network via the RJ45 port provided in the device, the necessary settings can be done here.
Wi-Fi icon	Opens the Wi-Fi settings for the gateway. Select a known network or add a new network.
Date and time icon	Opens the date and time settings.

3. Return to the start page from the settings by pressing the [Settings] icon again.

Configure cellular (SIM) settings

Cellular communication is used as standard in the gateway.

NOTICE Usually there is no need to change the cellular settings. A SIM card is provided with the gateway, there is no need to change the SIM card. Only skilled personnel are allowed to change these settings.

If you must change the cellular settings, follow these instructions:

1. Press the [Cellular] icon to access the cellular settings.
2. If the SIM card is locked, enter the SIM PIN to access the cellular settings.
By default, the SIM card is not locked.

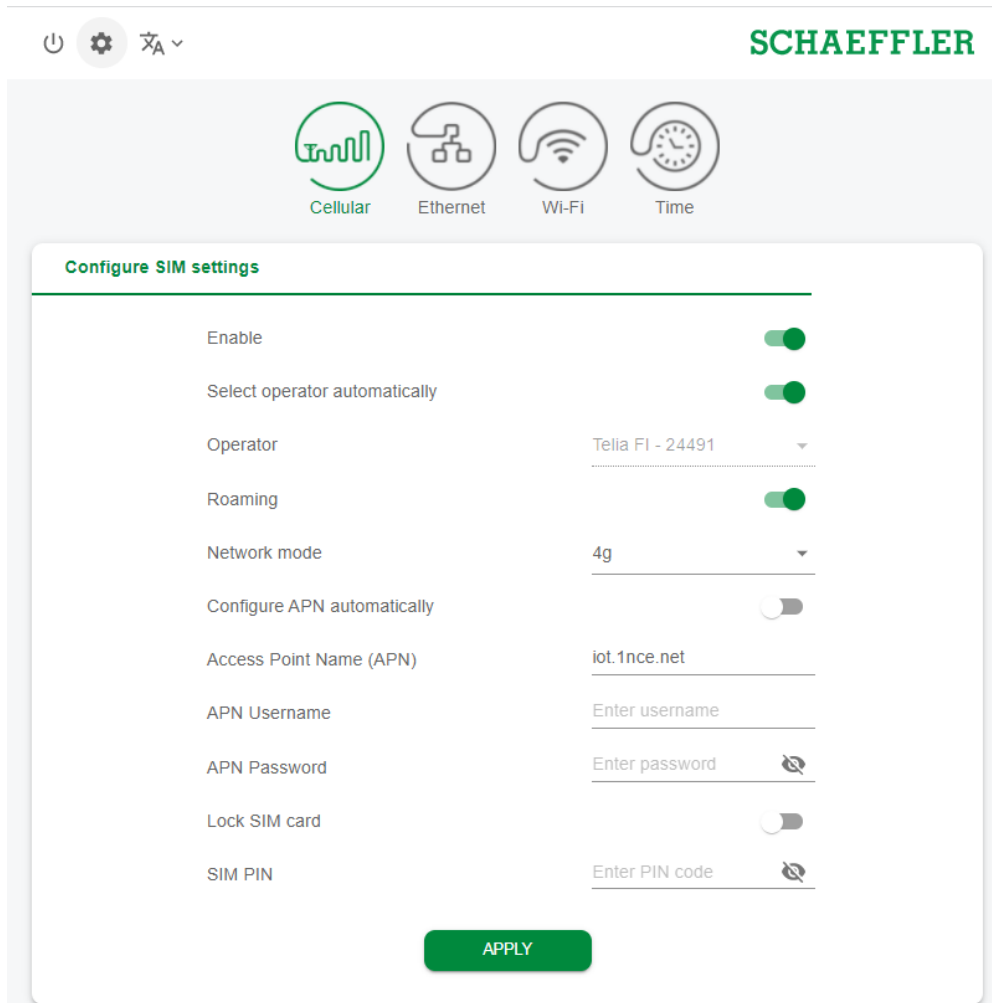

Figure 17 Configure SIM settings

3. If you need to add a specific provider, then disable the [Select operator automatically] selection and select the operator manually from the [Operator] list.
4. To avoid roaming charges abroad, disable the [Roaming] selection.
5. To manually select the Access Point Name (APN) of your network provider, disable the [Configure APN automatically] selection. Write the new APN on the line that opens.
6. Press [Apply] to save the changes to the configuration.

Configure LAN settings

Configure the LAN settings (LAN1; LAN2 is not yet enabled) if you want to use the company network.

1. Press the [Ethernet] icon to access the LAN settings.

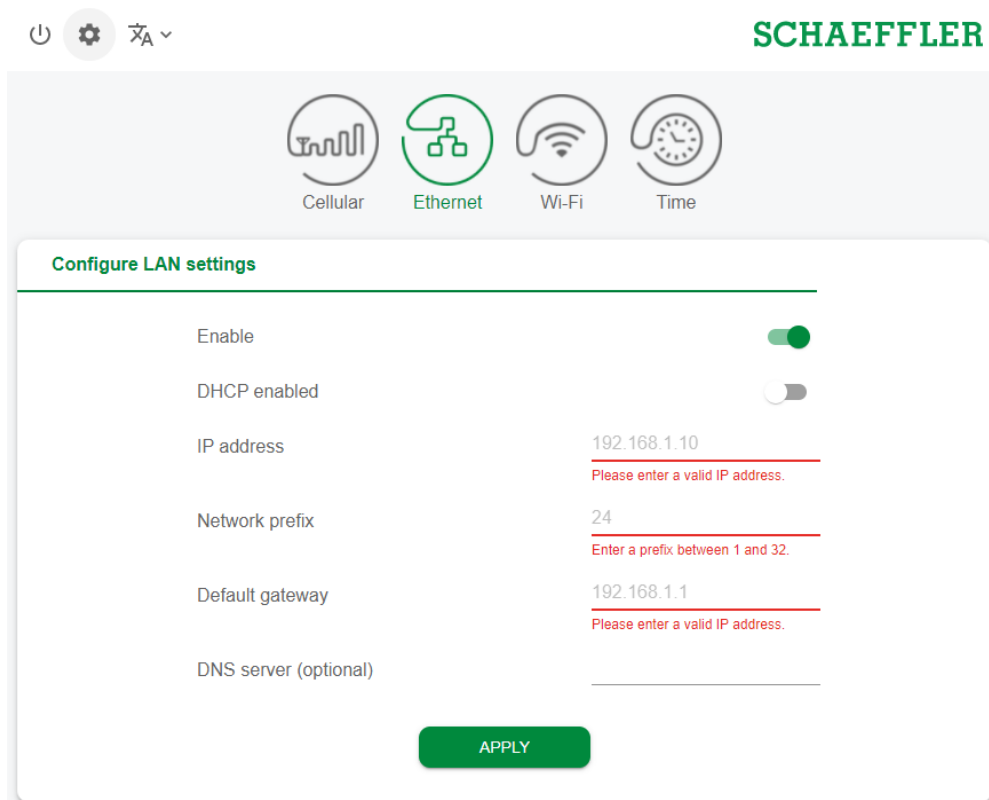

Figure 18 Ethernet (LAN) settings

2. Enable/disable DHCP. It is recommended to keep DHCP enabled. If you disable DHCP, enter the IP address of the network, the network prefix and the IP address of the gateway.
3. Enter the DNS server address, if needed.
4. Press [Apply] to save the changes to the configuration.

Configure Wi-Fi settings

To access the Wi-Fi settings:

1. Press the [Wi-Fi] icon to enable the Wi-Fi configuration mode.

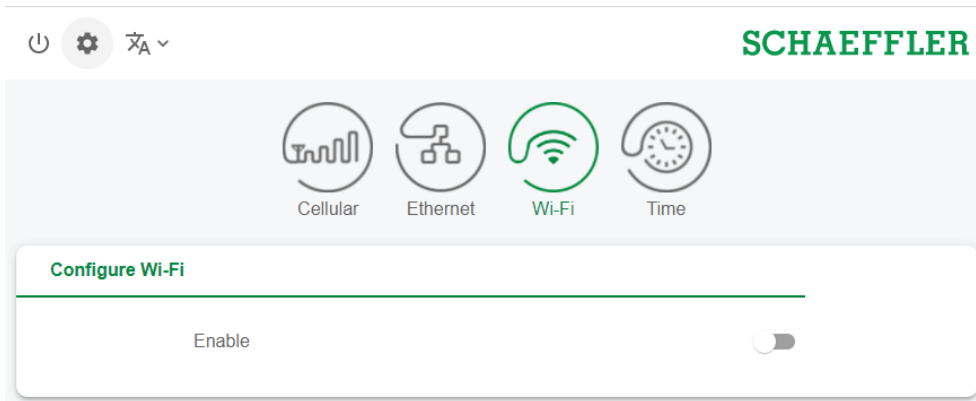

Figure 19 Configure Wi-Fi

2. Enable/disable the Wi-Fi settings.

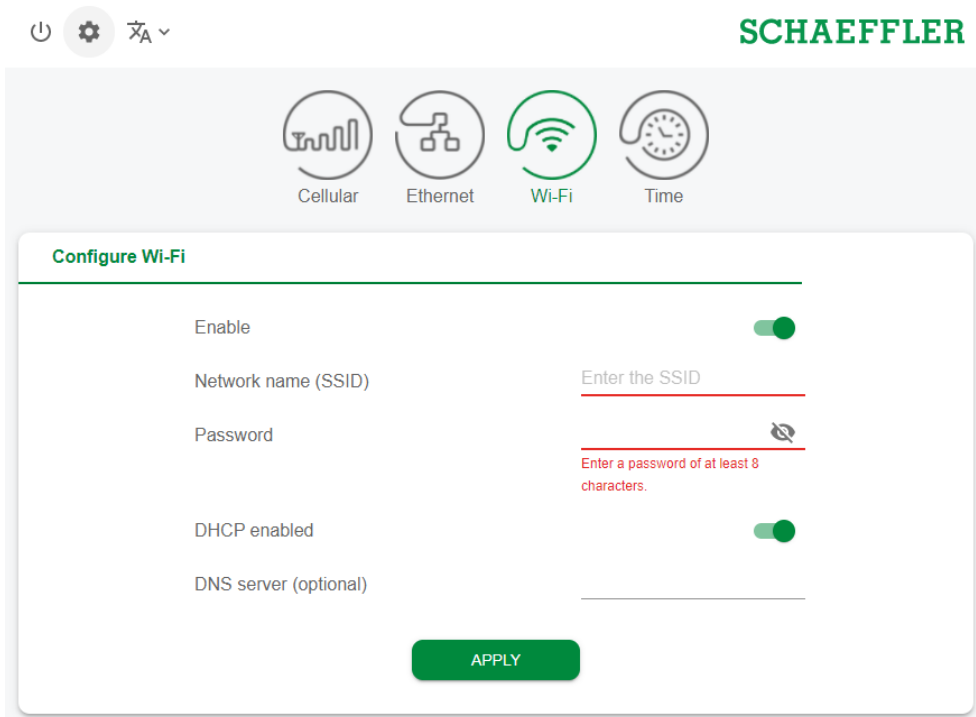

Figure 20 Wi-Fi settings

3. Change the Wi-Fi settings as needed:

Designation	Description
Network name (SSID)	Enter the name of the network.
Password	Password to the selected network.
Enable DHCP	Enable/disable DHCP. It is recommended to keep DHCP enabled. If you disable DHCP, enter the IP address of the network, the network prefix and the IP address of the gateway.
DNS server (optional)	Enter the DNS server address, if needed.

4. Press [Apply] to save the changes to the configuration.

Configure date and time

1. Press the [Date] icon to configure the date and time.

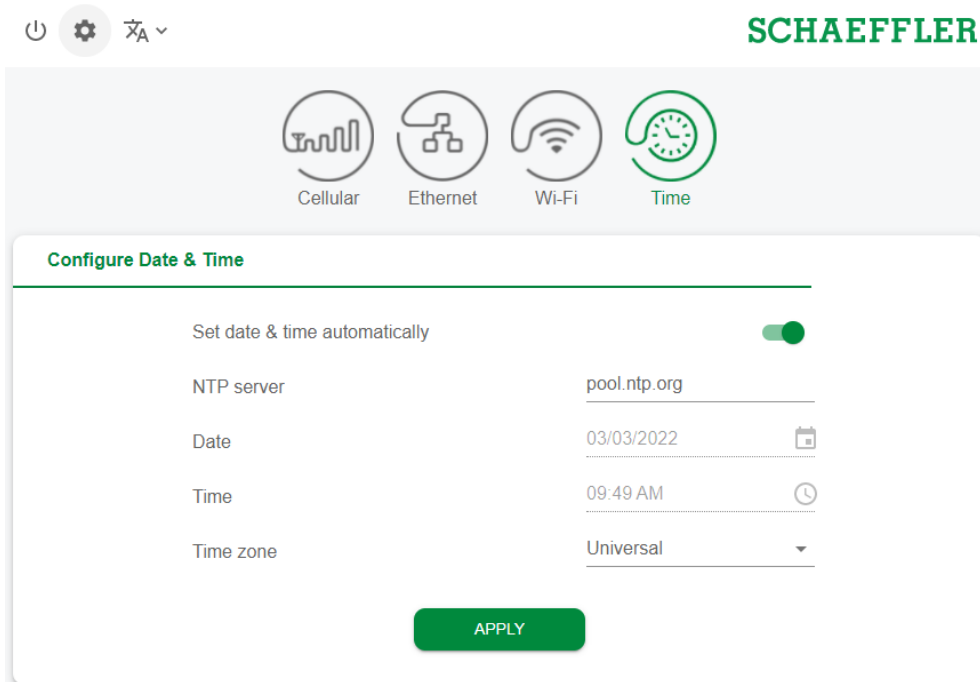

Figure 21 Configure date and time

2. Enable/disable to set the date and time automatically.
3. To change the Network Time Protocol, type the name of the server in the [NTP server].
4. To change the time zone, select the correct time zone from the list. To narrow down the selection, start typing the name of the time zone.

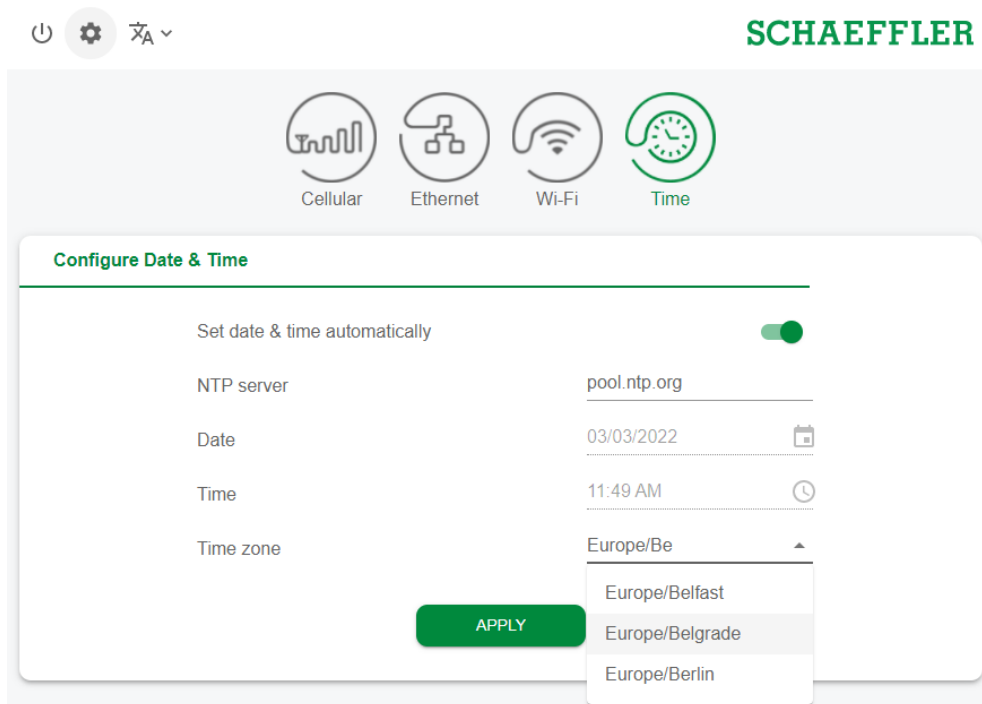

Figure 22 Time zone selection

5. Press [Apply] to save the changes to the configuration.

Change the language of the UI

To change the language of the gateway configuration UI

1. Press the [Language selection] icon and select the language from the list. The language of the UI changes immediately.

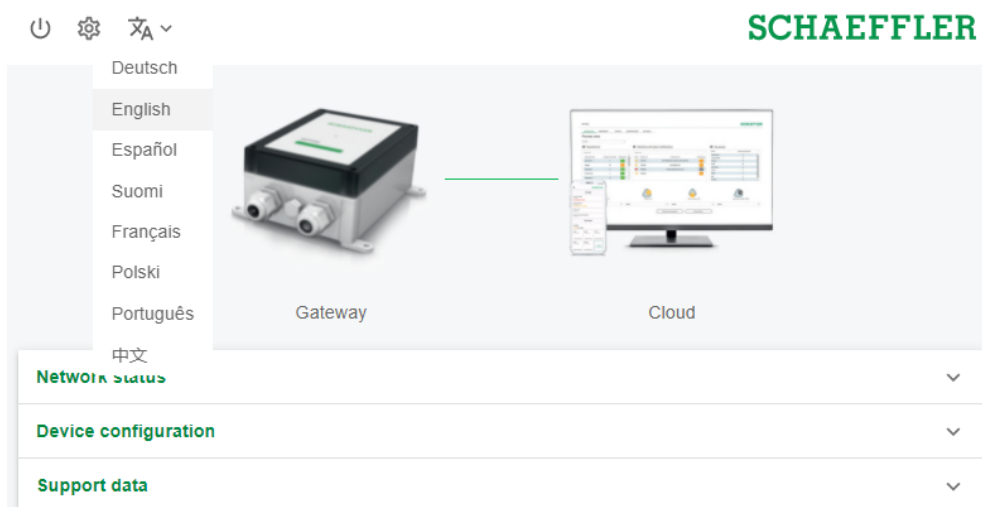

Figure 23 Language selection

Exit the configuration session

The connection ends automatically after 10 minutes of inactivity, or:

1. Exit the configuration session by pressing the [Exit] icon.

NOTICE If you exit the configuration session, you must reboot the gateway again to set it to the configuration mode and to reactivate the Wi-Fi access point.

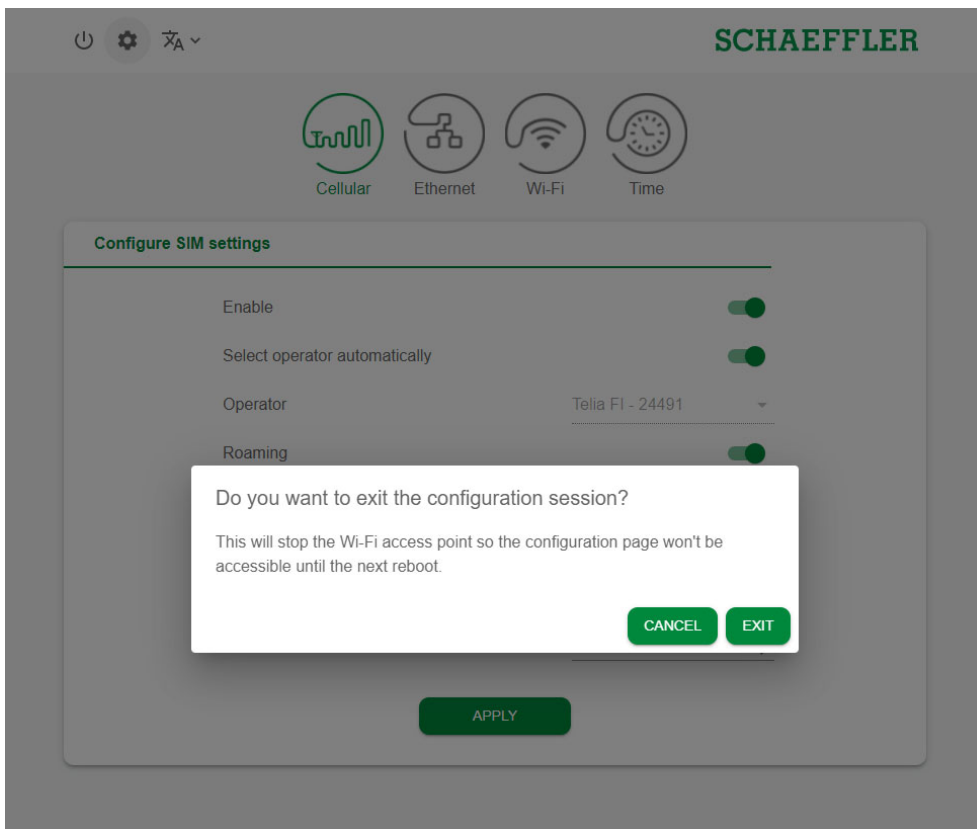

Figure 24 Exiting the configuration session

2. Confirm by selecting [Exit].

Troubleshooting and rectification

The Frequently Asked Questions (FAQ) on the OPTIME customer portal can assist with troubleshooting.

⚠ WARNING The incorrect handling of the gateway may result in leaks or the emission of evaporated electrolyte that can cause a fire or an explosion and lead to serious injuries or death. The gateway may only be returned following consultation with Schaeffler. It is imperative that the gateway is deactivated for return shipment. If there is a battery fault, shipping of the device is not permitted in accordance with the hazardous goods regulation. The gateway

and battery must be properly disposed of on site in accordance with the national disposal regulations.

Cleaning

You can clean the outside of the gateway housing if necessary.

- Disconnect the gateway from the mains before cleaning.
- Clean the gateway housing using a soft, lint-free cloth.
- Do not use any strong cleaning detergents or solvents.
- Do not use dripping wet cloths for cleaning.

Decommissioning

The gateway is maintenance-free. Gateways cannot be repaired.

Disposal

After use, dispose of the gateway in an environmentally compatible manner in accordance with the respective national regulations at your location.

If possible, dispose of the packaging material in the appropriate recycling waste.

When you finally decommission the product, find out more about the applicable disposal regulations from the recycling centre or from your specialist supplier.

Nameplate

The nameplate with the serial number (S/N) is located on the side of the housing. Beneath this is a QR code, in which the serial number is embedded.

Technical data

Designation	Value	Unit
Communication		
Wirepas Mesh (ISM band)	2,4	GHz
LTE, UMTS, GSM	•	–
Wi-Fi	2,4	GHz
Ethernet RJ45	•	–
SIM card format	Micro-SIM (3FF)	–

Electrical characteristics		
Protection class	□	-
Power consumption	20	VA
Power supply AC	100 to 240	V
Frequency	50/60	Hz
Power supply DC	10,8 to 13,2	V
Fuse	250 VAC, 1,25 A, 1500 VAC _{interrupt. rating} , certified in UL category JDYX2	-
Backup battery for RTC	Lithium 3,0 VDC, 10 mA max. charge, 210 mAh, -40 to +125 °C	-
Ambient conditions		
Ingress protection	IP66, Type 4X	-
Max. altitude	5.000	m
Operating temperature	-20 to +70	°C
Storage	Temperature	-40 to +85
	Humidity	20 to 90
		°C
		%
Dimensions, mass		
Length	210	mm
Width	180	mm
Height	77	mm
Mass	≈ 1,2	kg
Certificates		
CE, UKCA, FCC compliant		

 **CAUTION** Risk of fire or explosion if the battery is replaced by an incorrect type.

Gateways dimensions

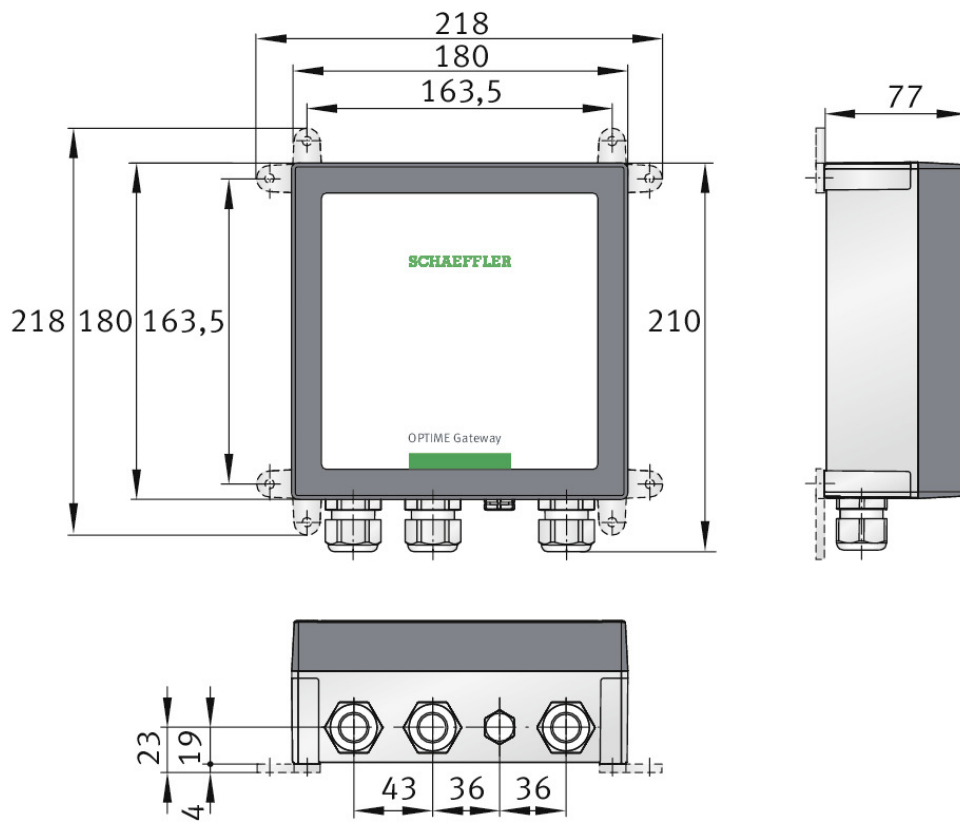

Figure 25 Gateway dimensions

Appendix

EU Declaration of Conformity

SCHAEFFLER

**EU-Konformitätserklärung
EU Declaration of Conformity**

Hiermit erklären wir in alleiniger Verantwortung, dass die mit CE gekennzeichneten Produkte
We declare under our sole responsibility that the CE marked products

Typenbezeichnung Type Description	Optime Gateway 2
Beschreibung Description	IoT Gateway
Hersteller Manufacturer	Schaeffler Monitoring Service GmbH, Kaiserstrasse 100, 52134 Herzogenrath

die grundlegenden Schutzanforderungen der folgenden Richtlinien erfüllen: Comply with the essential protection requirements of the directives		Harmonisierte Normen Harmonized Standards
2014/53/EU	Funkanlagenrichtlinie (RED) Radio Equipment (RED)	EN 300 328 V2.2.2 EN 300 330 V2.1.1 EN 301 511 V12.5.1 EN 301 908-1 V15.1.1
2011/65/EU	Gefährliche Stoffe (RoHS) Hazardous substances (RoHS)	EN IEC 63000:2018
2014/35/EU	Niederspannungsrichtlinie (LVD) Low Voltage Directive (LVD)	EN 62368-1:2014 EN 62368-1:2014/AC:2015 EN 62311:2008 ⁽¹⁾
2014/30/EU	Elektromagnetische Verträglichkeit (EMV) Electromagnetic Compatibility (EMC)	EN 301 489-1 V1.9.2 ⁽²⁾ EN 55032:2012 EN 55032:2012/AC:2013 EN 55022:2010, EN 55022:2010/AC:2011 EN 55011:2016, EN 55011:2016/A1:2017, EN 55011:2016/A11:2020

⁽¹⁾ Schutzziele aus EN 62311:2008 erfüllt durch Einhaltung von EN IEC 62311:2020
Safety objectives of EN 62311:2008 fulfilled by compliance with EN IEC 62311:2020

⁽²⁾ Schutzziele aus 2014/30/EU erfüllt durch Einhaltung von EN 55016-2-1, EN 301 489-1 V2.2.3 (2019-11)
Safety objectives of 2014/30/EU fulfilled by compliance with EN 55016-2-1, EN 301 489-1 V2.2.3 (2019-11)

Datum: 1.03.2023

Unterschrift:



Dr. Philipp Jussen
Geschäftsführer

Schaeffler Monitoring Services GmbH
Kaiserstrasse 100,
52134 Herzogenrath

Unterschrift:



i.v. Dipl. Ing. Götz Langer
Leiter Entwicklung (CE-Bevollmächtigter)

Schaeffler Monitoring Services GmbH
Kaiserstrasse 100,
52134 Herzogenrath

Diese Erklärung bescheinigt die Übereinstimmung mit den genannten Richtlinien, beinhaltet jedoch keine Zusicherung von Eigenschaften.
Das Produkt ist entsprechend der Inbetriebnahme-Vorschriften des Benutzerhandbuchs fachgerecht und korrekt zu installieren. Die
Sicherheitshinweise der Betriebsanleitung sind zu beachten.

UK Declaration of Conformity

SCHAEFFLER

UK- Declaration of Conformity

We declare under our sole responsibility that the UKCA marked product

Type Description OPTIME Gateway 2

Description IoT Gateway

Manufacturer Schaeffler Monitoring Services GmbH

Comply with the essential protection requirements of the Regulations	Designated Standards
Radio Equipment Regulations 2017	EN 300 328 V2.2.2 EN 300 330 V2.1.1 EN 301 511 V12.5.1 EN 301 908-1 V15.1.1
Hazardous substances Regulations 2012	EN IEC 63000:2018
Electrical Equipment (Safety) Regulations 2016	EN 62368-1:2014 EN 62368-1:2014/AC:2015 EN 62311:2008 ⁽¹⁾
Electromagnetic Compatibility Regulations 2016	EN 301 489-1 V1.9.2 ⁽²⁾ EN 55032:2012 EN 55032:2012/AC:2013 EN 55022:2010 EN 55022:2010/AC:2011 EN 55011:2016 EN 55011:2016/A1:2017 EN 55011:2016/A11:2020

⁽¹⁾ Safety objectives of EN 62311:2008 fulfilled by compliance with EN IEC 62311:2020

⁽²⁾ Safety objectives of Regulations 2016 fulfilled by compliance with EN 55016-2-1, EN 301 489-1 V2.2.3 (2019-11)

Date: 16.03.2023

Signature:



Dr. Philipp Jussen
Managing Director

Schaeffler Monitoring Services GmbH
Kaiserstrasse 100,
52134 Herzogenrath

Signature:



i.V. Dipl. Ing Götz Langer
Development Manager

Schaeffler Monitoring Services GmbH
Kaiserstrasse 100,
52134 Herzogenrath

This declaration certifies the compliance with the mentioned regulations but does not include any assurance of properties. The product must be installed correctly and professionally in accordance with the commissioning instructions in the user manual. The safety instructions in the operating manual must be observed.

Schaeffler Monitoring Services GmbH
Kaiserstraße 100
52134 Herzogenrath
Germany
www.schaeffler.de/optime

All information has been carefully compiled and checked by us, but we cannot guarantee complete accuracy. We reserve the right to make corrections. Therefore, please always check whether more up-to-date or amended information is available. This publication supersedes all deviating information from older publications. Printing, including excerpts, is only permitted with our approval.
© Schaeffler Monitoring Services GmbH

GW2 / 01 / en-GB / DE / 2023-04-17